

# THE ULTIMATE WHOLE TREE CHIPPER



**Model 3590XL**  
Whole Tree Chipper



## Fully Load Trailers With No Auxiliary Chip Accelerators

Proprietary designs for Bandit chipping drums, transitions and discharges provide an uninhibited flow of chips from the knives, delivering aggressive chip throwing power without any need for add-on accelerators or blowers. These devices can rob as much as 100 horsepower from the engine to operate, reducing production while also significantly increasing fuel consumption. Even with 1200 horsepower, the Model 3590XL uses approximately 30 percent less fuel per ton than competitive chippers. The uninterrupted throwing power also packs an additional three tons per load, which adds up quick!

## Easily Chip Full Grapple Loads & Nasty Tops

The aggressive five-wheel Slide Box Feed System on the Model 3590XL utilizes a durable infeed chain, bottom feed wheel, two vertical feed wheels and two top feed wheels set on an angle to easily climb material. The pulling and crushing power of this feed system is unmatched, allowing operators to feed the 3590XL full grapple loads of multiple whole trees and forked tops at one time. Virtually no prep work is needed to feed material, and the 3590XL chips with a smooth flow that experiences very few hang-ups.

## Synchronized Feed Systems Deliver Greater Efficiency With A Better End-Product

The Slide Box Feed System controls the flow of wood to within inches of the chipper knives and is synchronized to deliver material just as the chipper wants it. Wood is never pushed against the drum, which can have a braking effect that reduces both chipping power and fuel economy. Wood is also never held back from the drum, which can create fines and poor chip quality.

## Clean Feed System Increases Yield By As Much As 5%

Bandit's Clean Feed system virtually eliminates chip carry-around and unintended chip discharge under the infeed area. Capturing these chips normally lost by other chippers will increase yield by as much as 5 percent. It's like giving yourself a 5 percent raise with each load!

## The Bandit Backbone™ Support

The Bandit Backbone is Bandit's commitment to customer service and support. It's always been a cornerstone of Bandit's philosophy, and today that backbone is stronger than ever. If you own a Bandit hand-fed chipper – regardless the age, hours, or warranty status – the Bandit Backbone is here to support you.

# WHOLE TREE SPECIFICATIONS 3590XL

## ENGINES:

- TOWABLE:**
- 800HP Tier 2
  - 875HP Tier 2
  - 875HP Tier 4 Final
  - 1050HP Tier 2
  - 1050HP Tier 4 Final
  - 1200HP Tier 2
  - 1200HP Tier 4 Final

## UNDERCARRIAGES:

- TOWABLE:**
- AXLE** - (3) 25,000 pound axles
  - TIRES** - (12) 11R x 22.5 tires mounted on dual rims

## MEASUREMENTS:

[ Weight varies depending on engine ]

	TOWABLE:
Length:	43' 6"
Width:	11' 10"
Height:	12' 5"
Weight:	76,000 lbs
Fuel Tank:	350 gal
Hyd.Tank:	200 gal

## FRAME:

Mainframe: 1/2" x 6" x 10" rectangular tubing

## OTHER SPECIFICATIONS:

Max Feed Rate:	95 ft/ min
Capacity:	36"
Chipper Opening:	36" x 48" wide
Drum:	48" diameter x 48" wide
RPM:	840 Apx.
Feed System:	Slide Box
Feed Wheels:	(2) horizontal top (2) side vertical, 48" x 15 3/4" diameter top, 48" x 15 3/4" diameter top climber wheel
Hydraulic Motors:	4
Displacement (CID):	Top feed wheel features (2) 63.9 CID hydraulic motors, and each side feed wheel features (1) 63.9 CID hydraulic motor
Discharge:	Stationary
Deflector:	Up/down and side to side hydraulic chip deflector
Hitch:	Fifth wheel pintle hitch
Tongue Jack:	(2) hydraulically operated front stabilizer

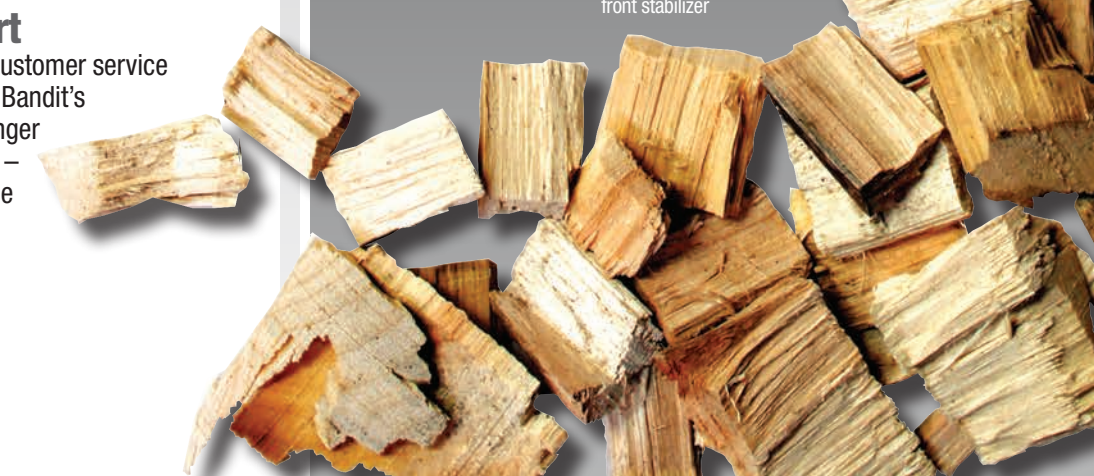

## PRODUCE UNIFORM CHIPS FROM 1/4" - 1" IN SIZE

The standard Bandit chipping drum produces a highly uniform wood chip in the normal 3/4" to 1" size range to serve many chip markets. A micro chip drum option is available, providing double the cuts per revolution to create a highly uniform 1/4" micro chip used in pellet production and other fuel wood markets. The micro chip drum is easily converted to produce a standard fuel chip by blocking half the knife pockets and adjusting the anvil. Combined with card breakers in the discharge to further reduce oversized material, the Model 3590XL produces exceptionally clean, uniform chips that are preferred in biomass applications.



## BANDIT WHOLE TREE CHIPPERS ARE KNOWN TO PRODUCE THE MOST UNIFORM CHIPS IN THE INDUSTRY



3/4" Standard chip



1/4" Micro chip

## THE BANDIT DRUM: Unmatched Reliability With Minimal Down Time

At the heart of the Model 3590XL is Bandit's legendary chipping drum. Bandit drums are constructed with oversized shafts and bearings, thick skins made with wear-resistant material, and a rigid internal baffling system that makes them virtually indestructible. These drums, along with the use of high quality materials, industry standard components and extensive welded construction, serve as the foundation for Bandit's proven reputation for durability and reliability. They're also the basis for Bandit's five-year GUTS warranty that covers the drum, feed systems and related components.

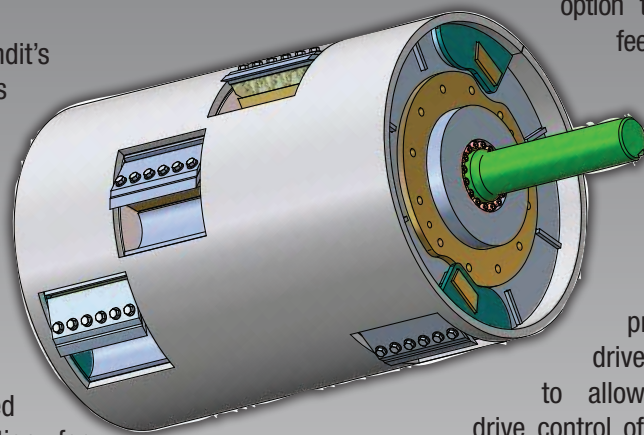

Model 3590XL Drum Diagram

### Optional Proportional Drive

Bandit's proportional drive system is an available option that automatically adjusts the feed speed to match engine RPM.

This allows a continuous, uninterrupted flow of material through the chipper regardless of material, and is ideally suited for micro chip production. The proportional drive system is easily disengaged to allow the standard auto feed drive control of the feed system for optimal production of standard chip sizes.

# MODEL 3590XL

## 36" Capacity Whole Tree Chipper



## ACHIEVE MAXIMUM OPERATING EFFICIENCY WITH THE BIGGEST, BADDEST, MOST PRODUCTIVE CHIPPER AVAILABLE

Imagine chipping entire grapple loads of the roughest tops and slash at one time, filling trailers at rates exceeding 5 tons per minute with uniform chips ranging from 1/4" to 1" in length. The Model 3590XL can do this and more with a 36" by 48" throat opening, aggressive five-wheel feed system and engine options from 800 to 1200 horsepower. But the appeal of this chipper is more than just raw processing power—it also brings greater efficiency to the entire operation. Support equipment is constantly working to keep up with the chipper. Chip vans aren't sitting idle waiting for loads. The speed and productivity of the 3590XL increases the overall productivity of your operation, reducing labor costs per ton of material produced.



# Bandit INDUSTRIES, INC.

6750 Millbrook Rd. • Remus, MI 49340 • 1-800-952-0178

FIND US ONLINE    [WWW.BANDITCHIPPERS.COM](http://WWW.BANDITCHIPPERS.COM)

All specifications, dimensions and options are subject to change without notice, and were current at the time of printing. Dimensions may vary, depending on options and engines selected. Bandit Industries, Inc. reserves the right to change designs, specifications and options without prior notice. © 2016 Bandit Industries, Inc. All Rights Reserved.

**CALL YOUR LOCAL BANDIT SALES REPRESENTATIVE TO SCHEDULE A DEMONSTRATION TODAY!**

3590XL\_0416